

# Leclerc Looms

Since 1876



1573 Savoie  
C. P. 4 Plessisville, Qc.  
G6L 2Y6  
TEL: 819-362-7207  
FAX: 819-362-2045  
www.leclerclooms.com  
info@leclerclooms.com

## FANNY II

36"	1024-0136
45"	1024-0145
60"	1024-0160

On receiving the loom, unpack and lay out the loom components.  
Do NOT discard any packing material until all parts are inventoried.

Check the parts received against the parts list on pages #2 to #7 of the assembly instructions. Report any discrepancies to Leclerc immediately.

To assemble this loom, a minimum of 2 people are needed but it is recommended you use 3.



Loom Prepared by: \_\_\_\_\_

Inspected by: \_\_\_\_\_

Date: \_\_\_\_\_

Serial No: \_\_\_\_\_

# PARTS LIST

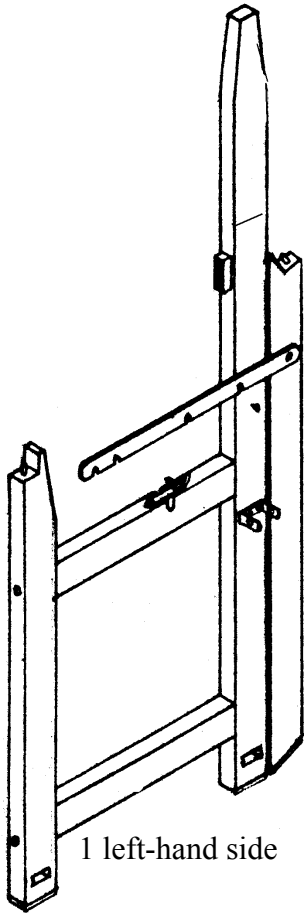

1 left-hand side

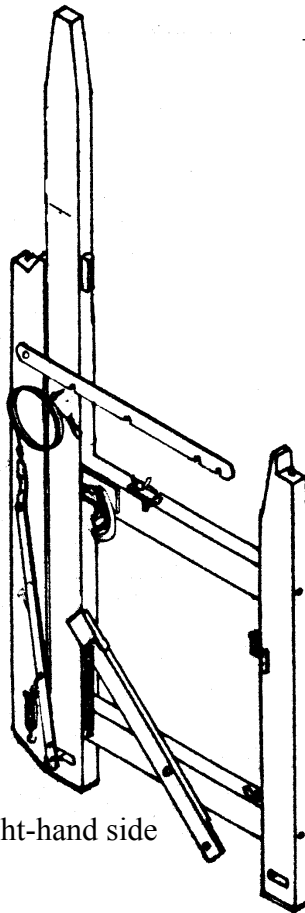

1 right-hand side

LECLERC NOTE IN FRENCH:

- 1- Faire les avant-trous pour le frein d'ensouple.
- 2- Faire les trous pour baguette d'encroix.
- 3- Faire le trou sur le montant centre pour l'attache du ressort de régulateur 1" plus haut que le crochet arrière.
- 4- Faire les avant-trous sur la patte arrière pour le système de contrôle de rotation de l'ensouple arrière.

6 treadles



2 metal treadle supports



1 treadle set rod 19 3/4" with  
1 Push nut 7/16"



1 more treadle set  
push nut 7/16"



1x warp beam advance control system  
2x screw no 12, 1"



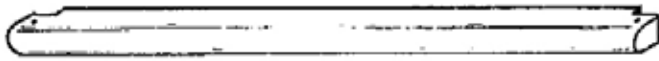

2 breast beams  
(43 1/2", 52 5/8", 68 1/8")

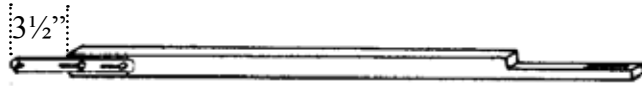

1 left sword (32 1/2")



1 right sword (32 1/2")

Vérifier que les bagues entre bien dans les pattes et traverses

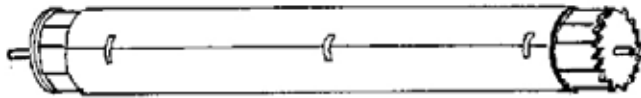

1 cloth (front) beam  
(38 1/2", 47 5/8", 62 9/16")

Avec Bagues (Bushings)



1 warp (back) beam  
(38 1/2", 47 5/8", 62 9/16")



1 batten handtree  
(46 3/4", 55 3/4", 70 3/4")

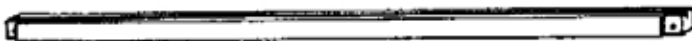

1 batten sley with shuttle race  
(46 3/4", 55 3/4", 70 3/4")

No holes across

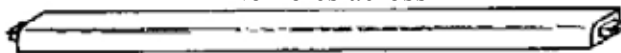

1 lower-middle cross-member  
(40 1/8", 49", 64")

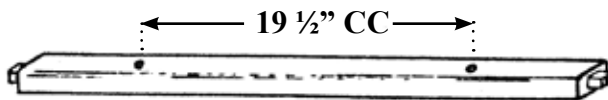

1 treadle set -cross-member  
(40 1/8", 49", 64")

2 holes for treadle set

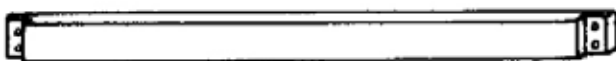

1 cross-board connecting the back posts (34 1/2", 52 5/8", 67 1/4")



1 apron

LECLERC NOTE:  
Rondelle de bois si nécessaire



1 cloth take-up motion handle

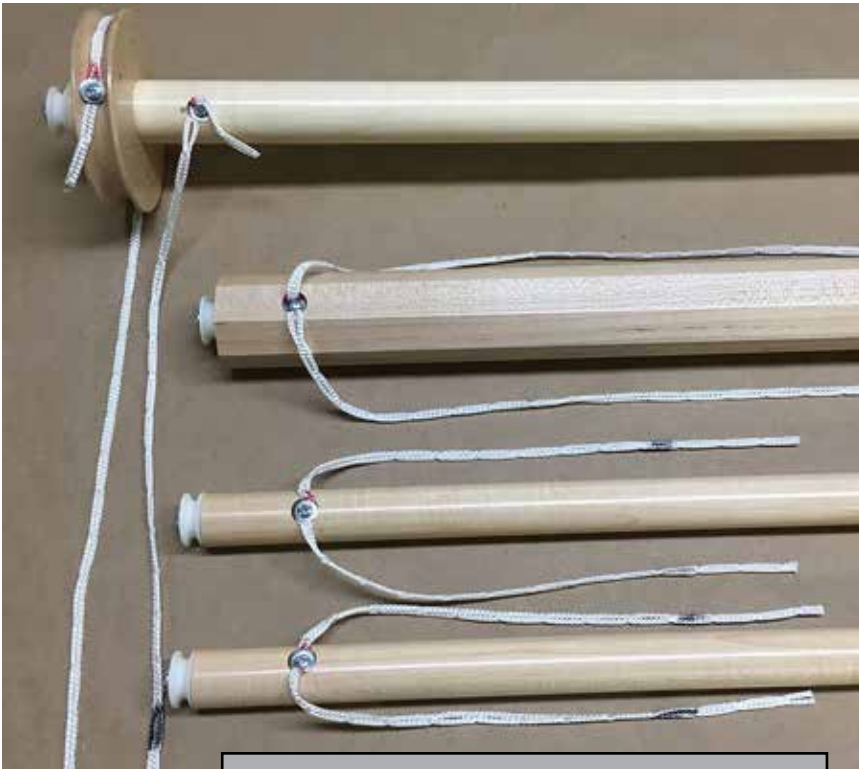

LECLERC NOTE:  
 Marques noires sur toutes les cordes.

1 shed regulator roller

1 octagonal roller with white pulleys

2 small rollers with white pulleys

1 left (G) roller support

1 right (D) roller support

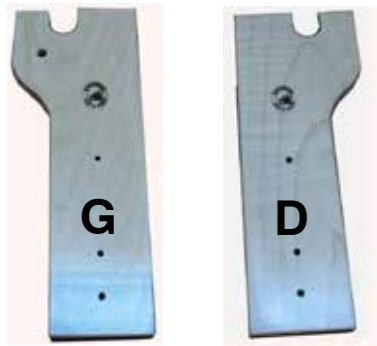

1 metal pin to lock shed reg. roller

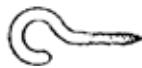

1 open eyehook



6 round-headed screws No 12, 1"

9 round-headed screws No 6, 1/2"



9 steel washers 3/16"



1 shed regulator spring

5.5" + Crochet en "S"

# PARTS LIST

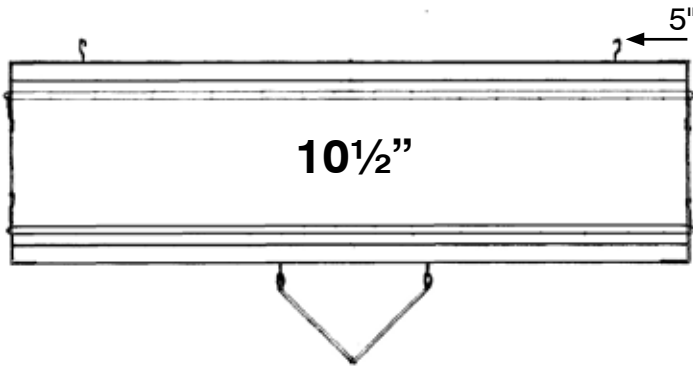

4 shaft frames



36" =  $26\frac{1}{4}''$  (cc  $18\frac{3}{4}''$ )  
 45" =  $30\frac{3}{4}''$  (cc  $23\frac{3}{8}''$ )  
 60" =  $38\frac{1}{4}''$  (cc  $31''$ )

4 lams



1 crank

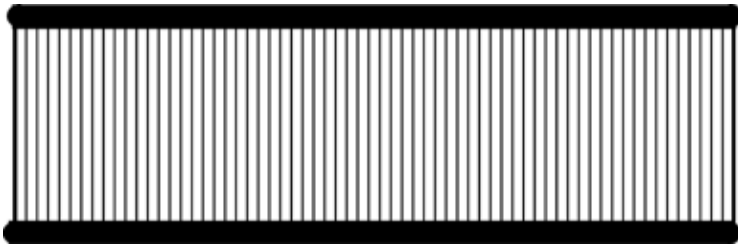

1 reed



2 lease sticks



4 warp rods  $\frac{5}{16}''$   
 +  $2\frac{7}{16}''$  for narrow weaving

# PARTS LIST



3 screwdrivers (Black, Red and Green)



1 clé en aluminium



1 adjustable wrench



1 set of 6 treadle hooks 7" # 3500-4521



1 sets of 12 treadle cords 7" # 3000-7011

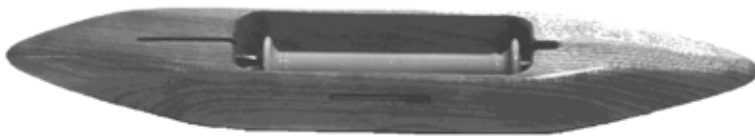

1 boat shuttle



12 plastic bobbins



1 threading hook



2 pkg of cords (5 yds each)



10½"

1000 heddles (36" loom)

1200 heddles (45" loom)

1500 heddles (60" loom)

# PARTS LIST

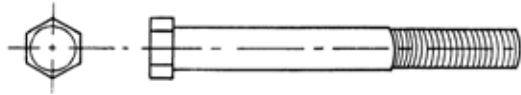

Machine bolts  
 4 X - 3/8" x 5"  
 1 X - 1/4" x 3"

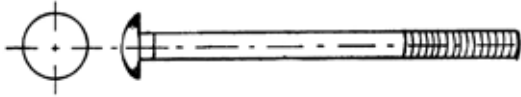

Carriage Bolts  
 6 X - 5/16 x 2 1/2"  
 2 X - 5/16" x 2 1/4"



Washers  
 10 X - 5/16"  
 4 X - 3/8"  
 1 X - 1/4"



HEXAGON NUTS  
 2 X- Nylon auto lock 5/16"



SQUARE NUTS  
 4 X - 3/8"  
 4 X - 5/16"  
 1 X - 1/4"

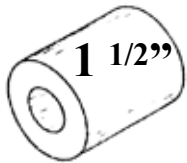

Wooden spacer  
 5 X



Wing nuts  
 4 X - 5/16" (8 mm)



USB key Instruction Video showing the Mira II (V. 2016)



Round head screw  
 4X - #12 x 1 1/2"



1 book Warp & Weave



2X eye screws



Tacks for canvas

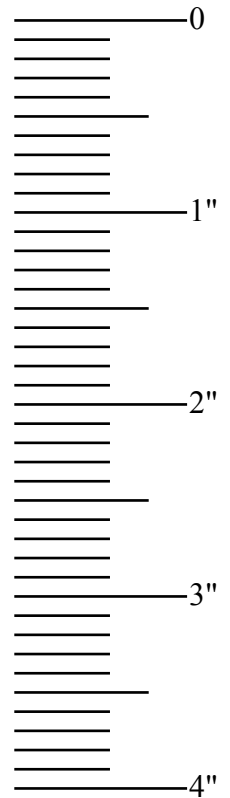

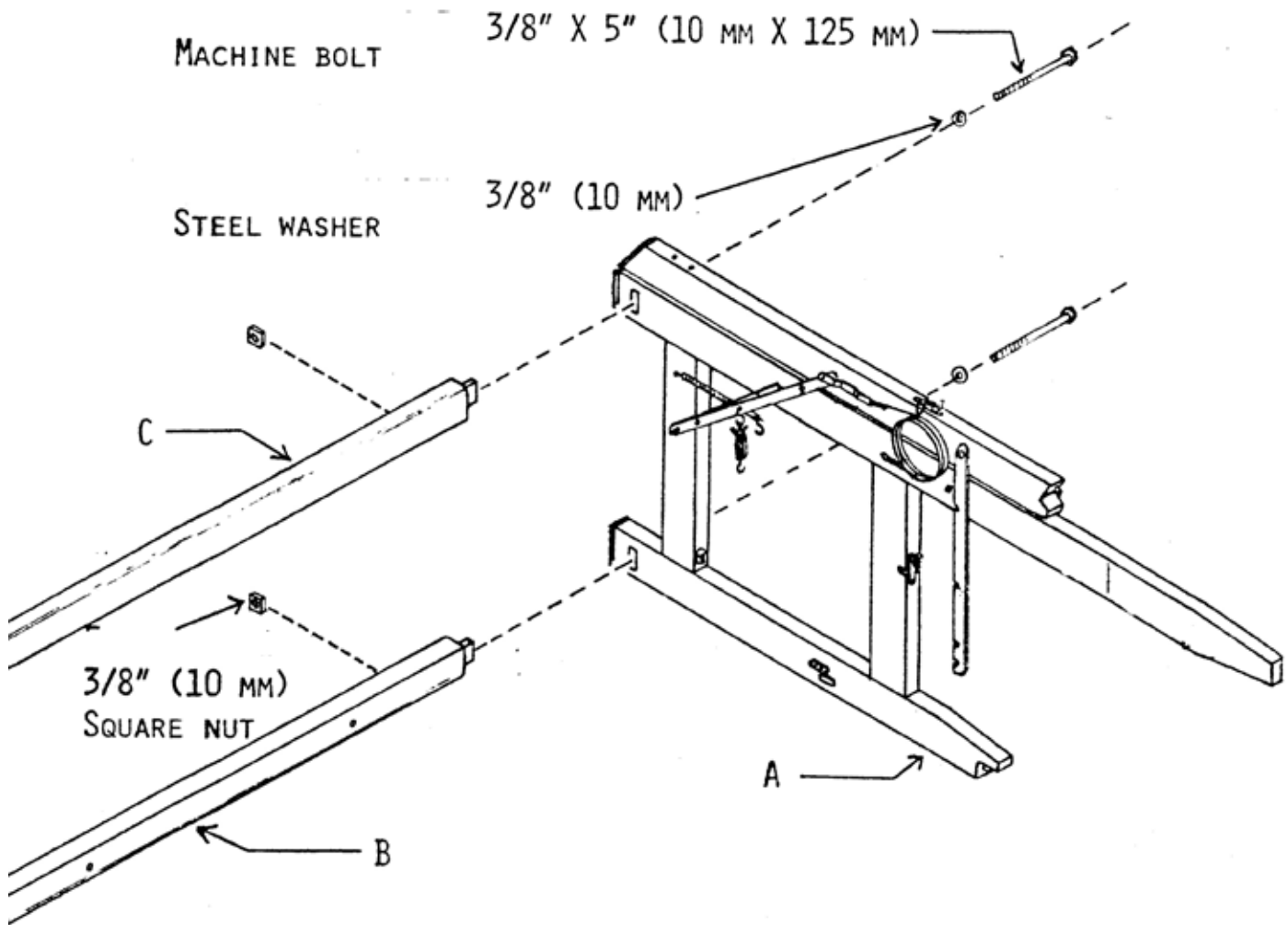

Place right-hand side A of the loom on its front.

Insert the tenon of lower cross-member B into the lower front mortise of right-hand side A.

**NOTE:**

The lower front cross-member has two holes drilled through it which are used to affix the treadle set.

Using the wrench supplied with the loom, affix cross-member B with a 3/8" x 5" machine bolt, a 3/8" steel washer and a square nut.

Repeat the sequence with cross-member C (no holes).



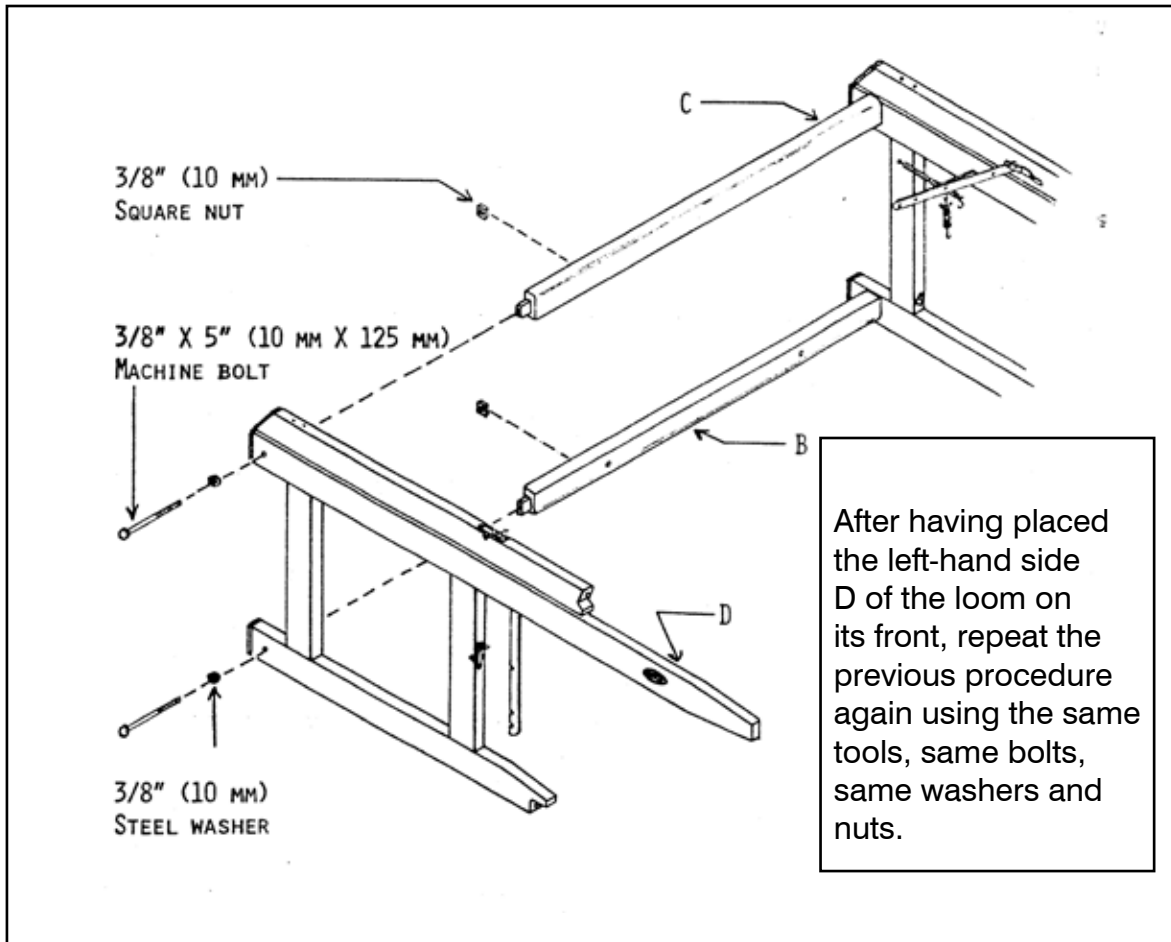

**ATTENTION: Application of soap to the screws will make their insertion easier.**

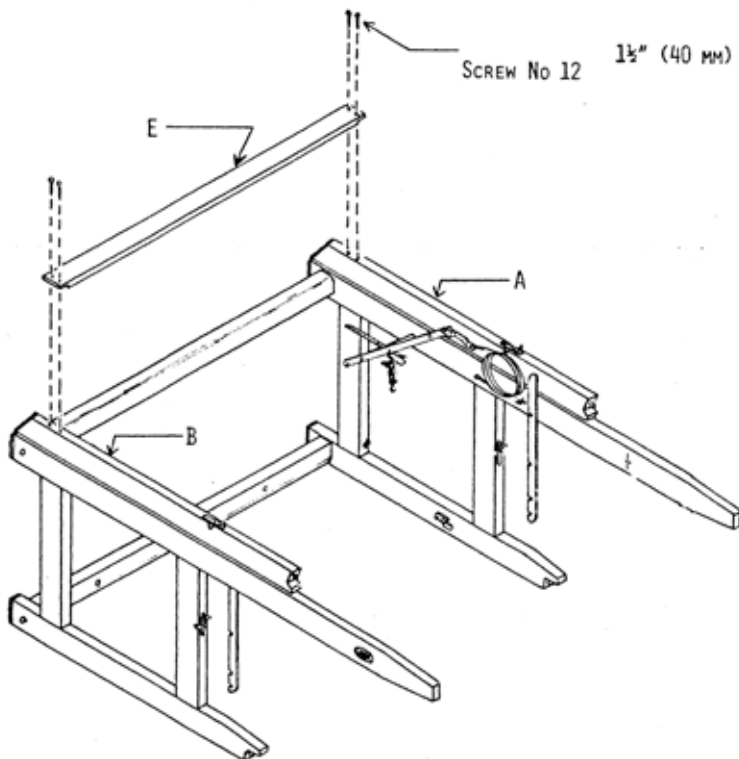

Using four 1 1/2" round-headed screws no. 12, affix back cross-member board E to back posts A and B.

NOTE:  
If cross-member board E does not fit between posts A and B, insert it higher between the posts, then slide it down.

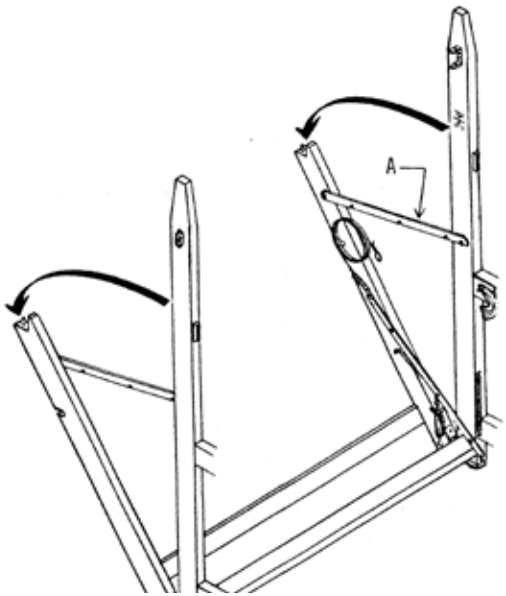

Unfold the back section of the loom (back posts) and lock it in place with metal hooks A.

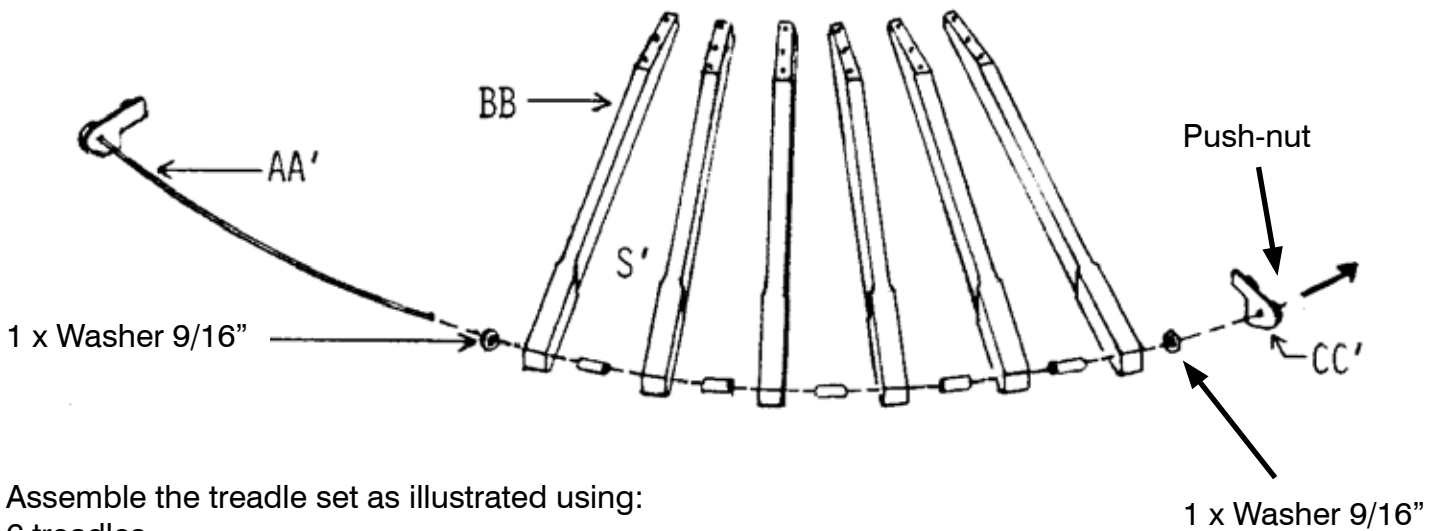

Assemble the treadle set as illustrated using:

- 6 treadles
- 5 wooden spacers 1 1/2"
- 1 Treadle rod pre-assembled
- 2 Steel Washers 9/16"
- 1 Push nut

Install the second side push nut only after the set is affixed to the loom.



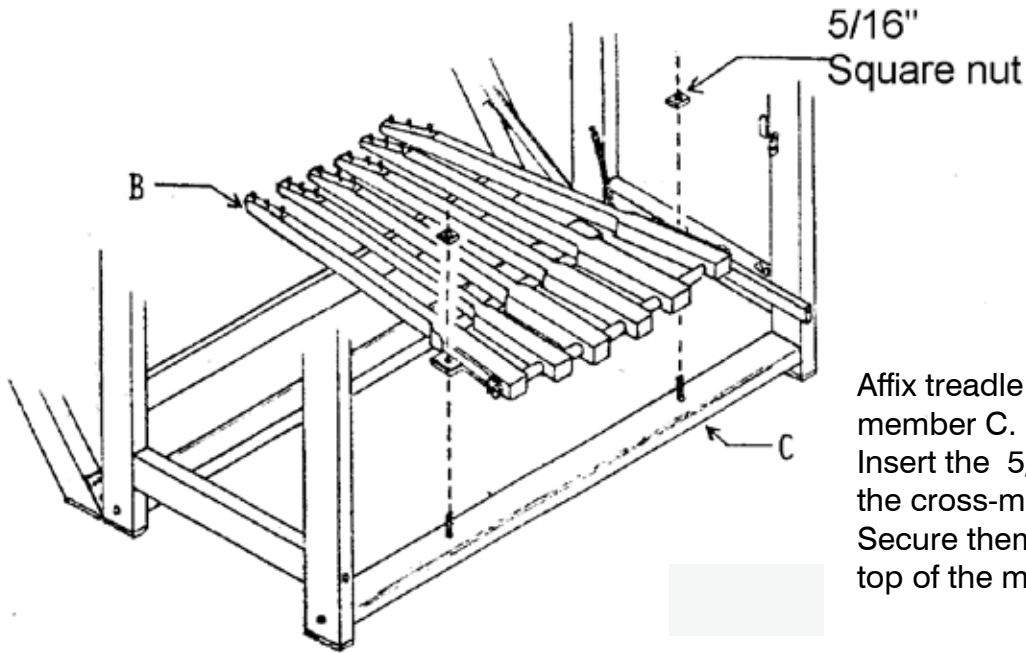

Affix treadle set B to lower front cross-member C. Insert the 5/16" x 2 1/2" bolts from under the cross-member. Secure them with the square nuts in the top of the metal treadle support.

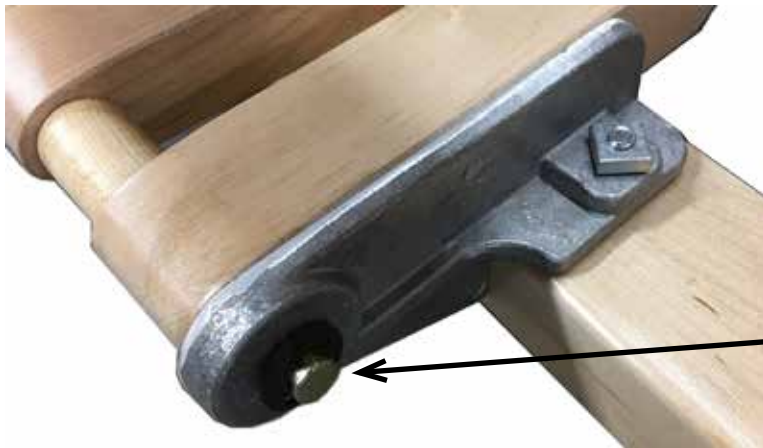

**Install the side push nut.**

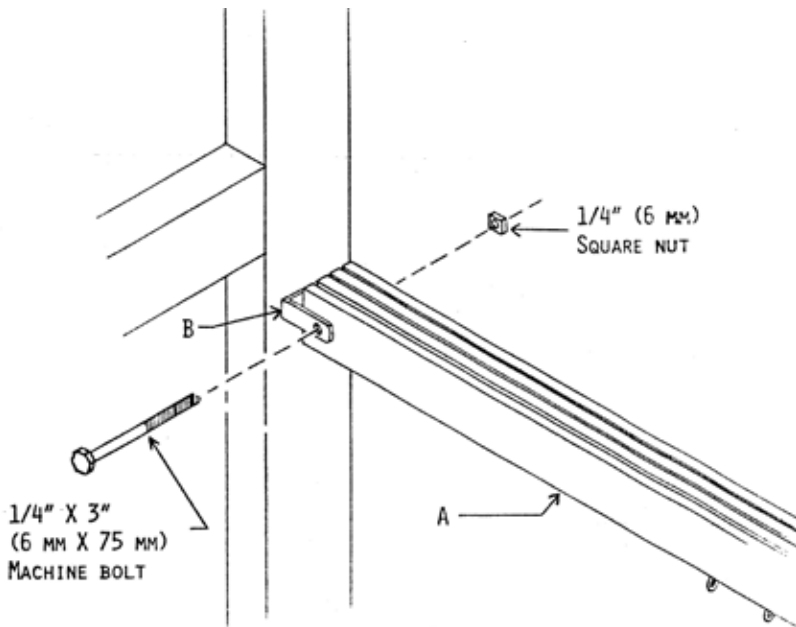

Using a 1/4" x 3" machine bolt and a 1/4" square nut, affix the four lams A to lam support B of the left-hand side main post.

NOTE: The upper side of the lams has a single eye screw.

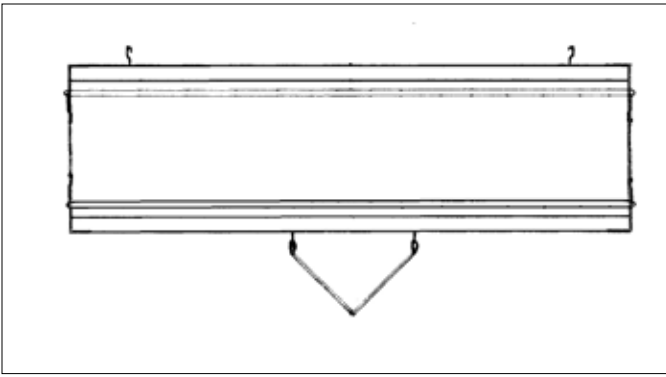

You can install now or later Install the heddles in the shaft frames  
(see Warp & Weave).

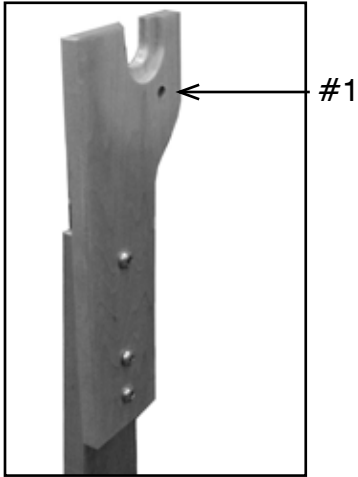

Note: The left hand side has a hole (#1) in the back of the board for the locking pin.

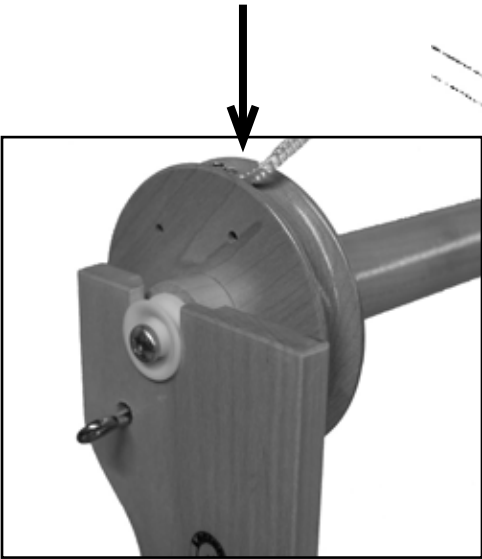
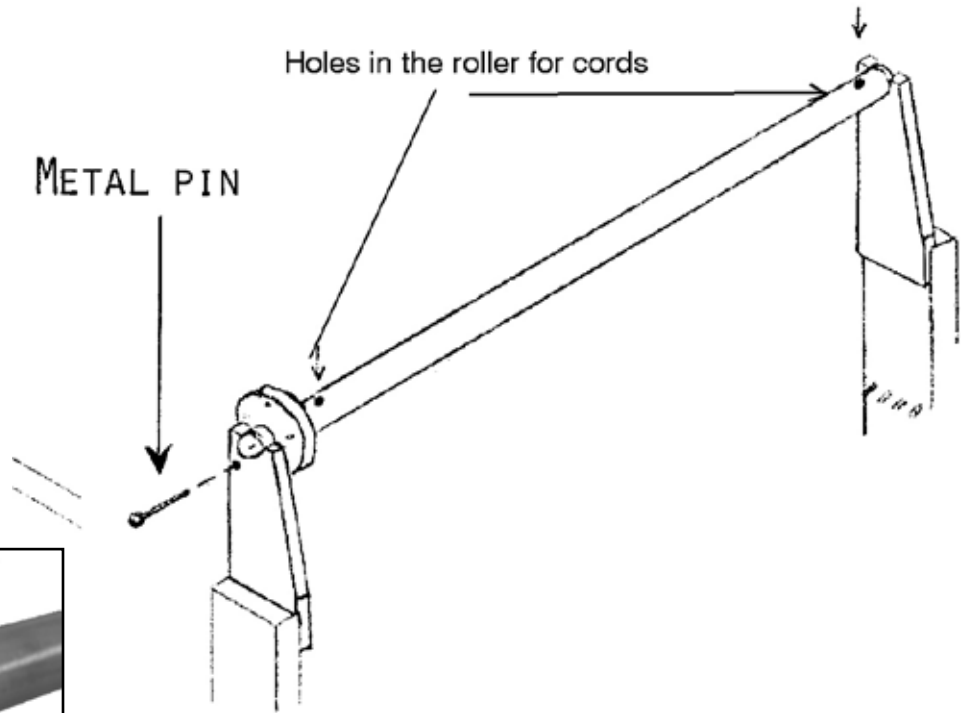

Using 6x 1" round-headed screws No 12, fasten the two roller supports to the center posts .

Place the shed regulator roller on the supports. The wood pulley should be on the left hand side of the loom.

Insert the 3" metal pin through the support and one of the holes of the wood pulley to lock while the washer and screw are above.



Make sure that the upper roller is locked when the washers and screws are up (above).

Turn the loop cord counterclockwise and make the loop at the black mark.

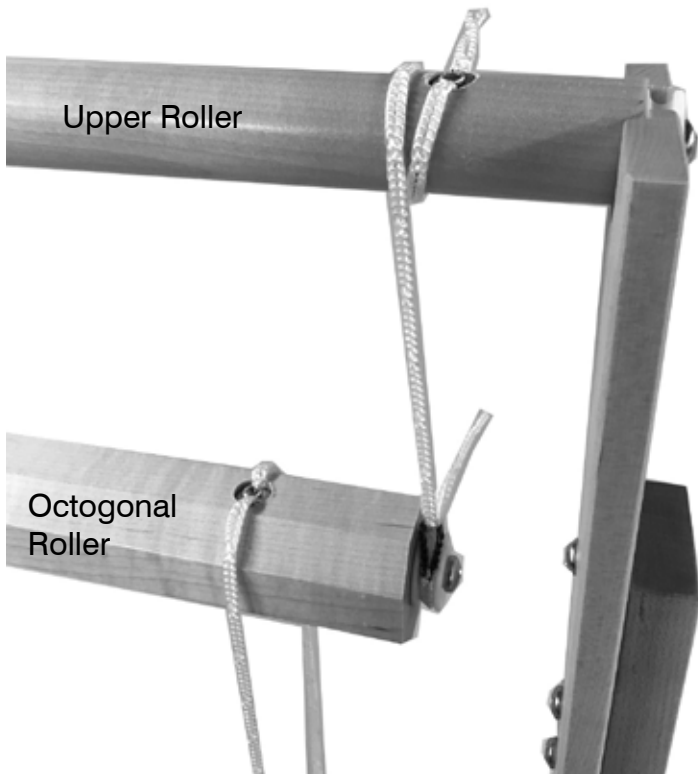

Install the Octogonal Roller Loop around the white pulley.

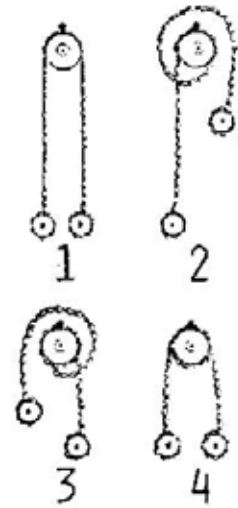

Make sure to have the washers and screw in up position.

Turn the loop cords around the Octogonal Roller as shown.

Make the loops at the black marks.

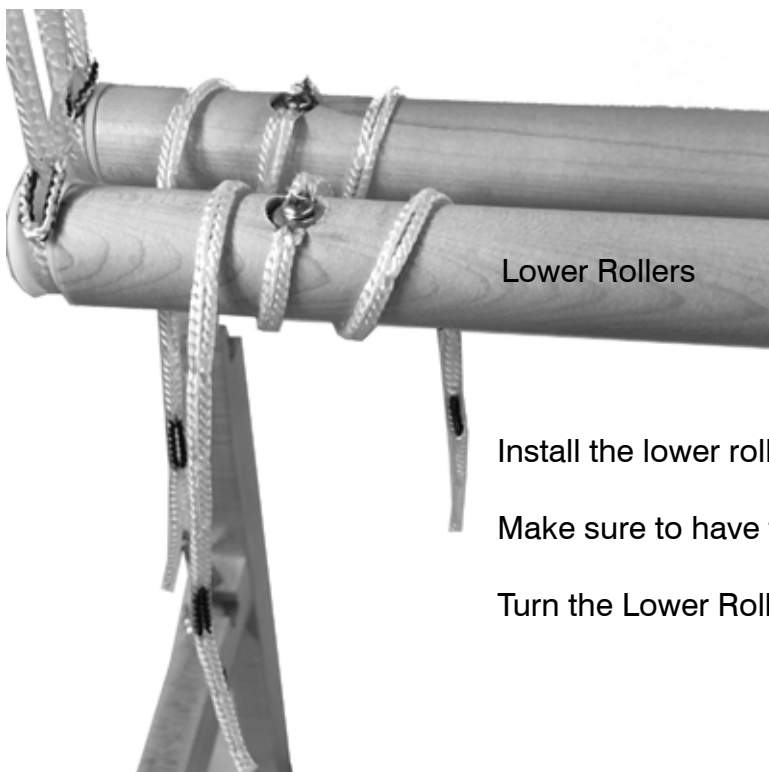

Install the lower rollers using the loops over the white pulleys.

Make sure to have the washers and screws are in the up position.

Turn the Lower Roller loop cords as shown.



Hook the shaft frames using the black marks of the loop cords.

The Leclerc logo should be facing the front of the loom.







Affix to the pre-drill hole of the main castle the open-end eyehook.

Turn the loop cord of the Regulator Roller one full turn counterclockwise.

Remove the locking pin and connect the spring from the open-end eyehook **to the black mark** of the loop cord so the shaft frame are about at the black line on the inside of the main uprights.



When you weave balance shed, you can lock the shed regulator in place.

When you weave unbalance shed, you have to unlock the regulator roller.



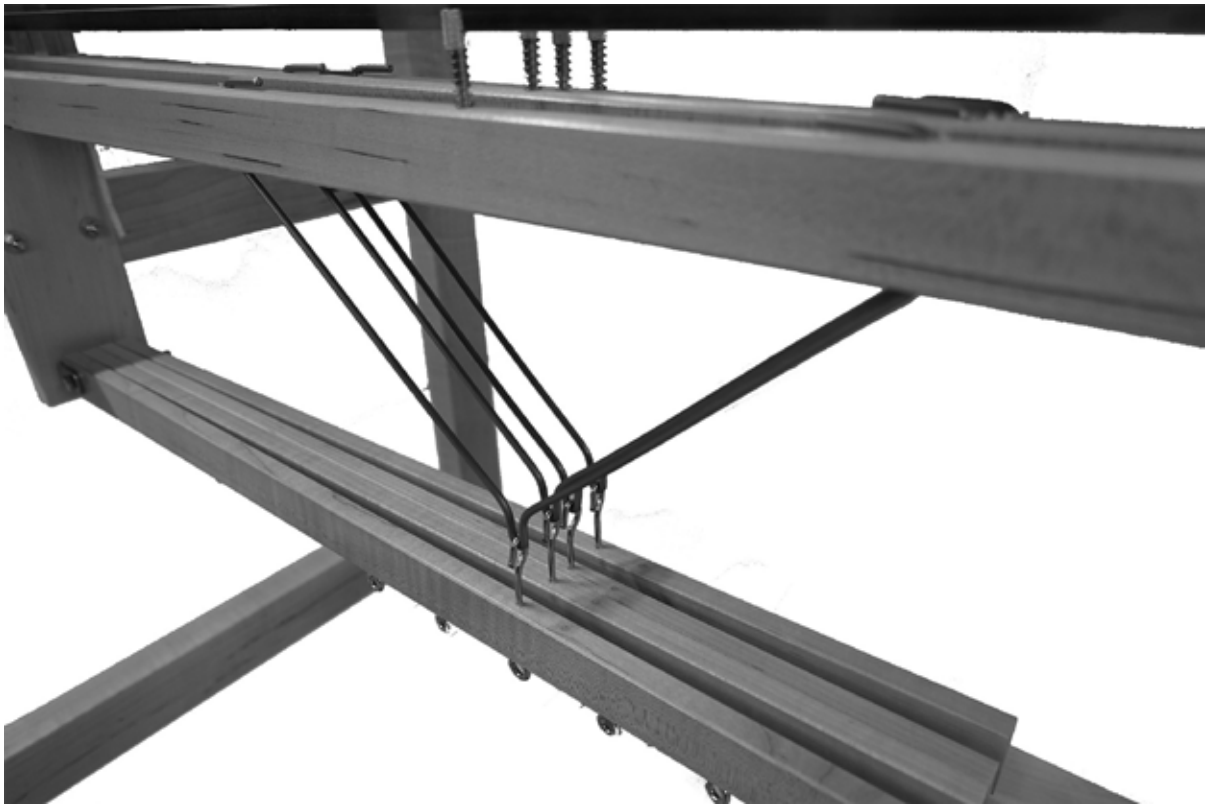

Connect the shaft frames to the lams

Your loom is now adjusted for a counter- balanced weave. If you wish to treadle one harness against three, you must engage the shed regulator by removing the metal pin from the pulley, and readjusting the tension of the spring (by inserting the “S” hook in different loops) to obtain the best possible shed.

The shed when using the un-balance shed and the shed regulator is smaller than balance shed but possible to weave with it.

When weaving balance treading, you can weave without the pin or with the shed regulator on.

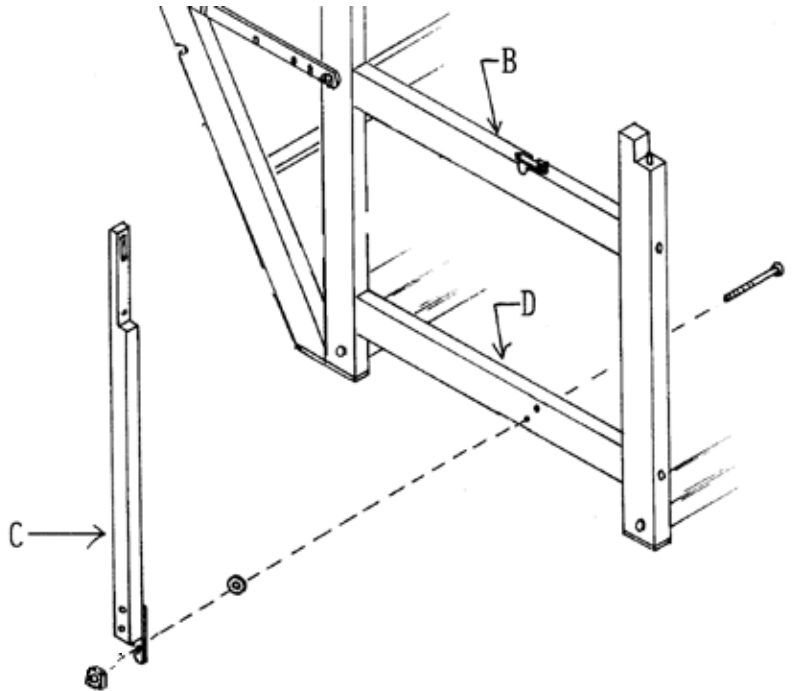
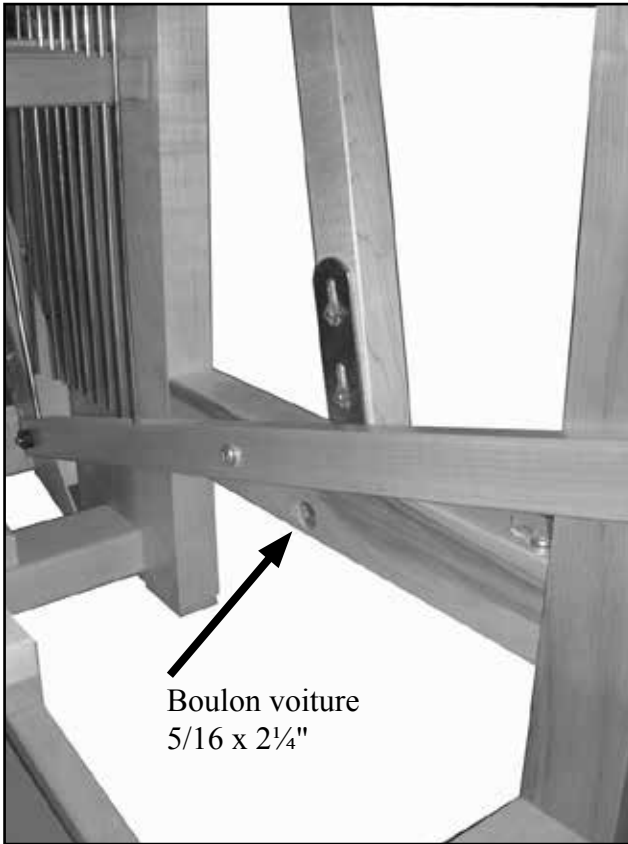

**NOTE: Hammer the carriage bolt inside the hole so it will lock while you will screw the auto lock nuts.**

Using 5/16" x 3 1/2" (8 mm x 89 mm) carriage bolts, affix swords A and B to lower front cross-members C and D. Insert the bolt from the inside into the **lower hole**.

Place a 5/16" (8 mm) steel washer between the cross-member and the sword.

Secure with a 5/16" (8 mm) hexagonal nut. Do not overtight since the swords should move freely.

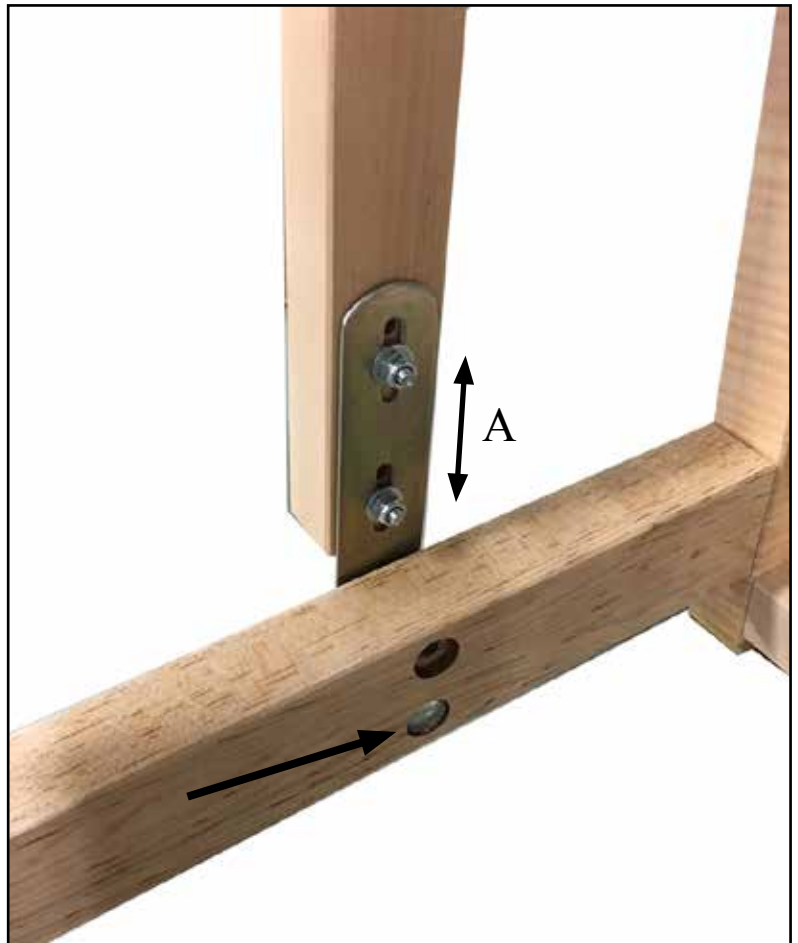

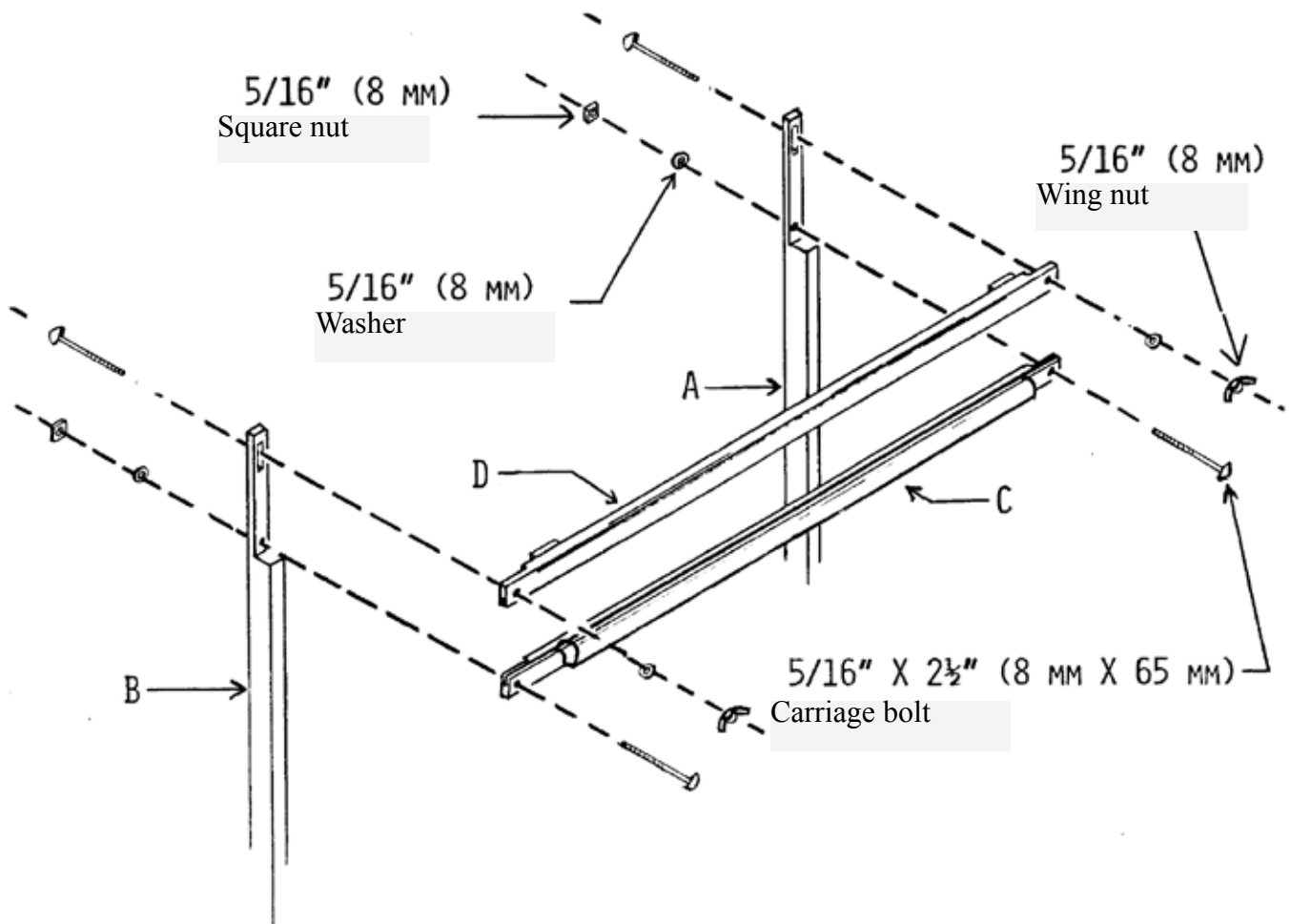

Affix batten sley A (with shuttle race) to the bottom of the batten sword grooves C. Insert a 5/16" x 2 1/2" carriage bolt into both ends of batten sley A, then into the hole at the bottom of the sword groove C. (The groove of sley A must be on the upper side.) Complete with washers and square nuts.

Affix batten handtree B to the slots on top of the sword grooves C. Insert a 5/16" x 2 1/2" carriage bolt into both slots of the batten sword C, then to the batten handtree. (The groove of the handtree A must be on the underside.) Complete with washers and wings nuts.

If the loom is equipped with a sectional warp beam, the rake-like pieces must be affixed to the warp beam. If not, affix the apron to the warp beam with the tacks supplied with the loom.

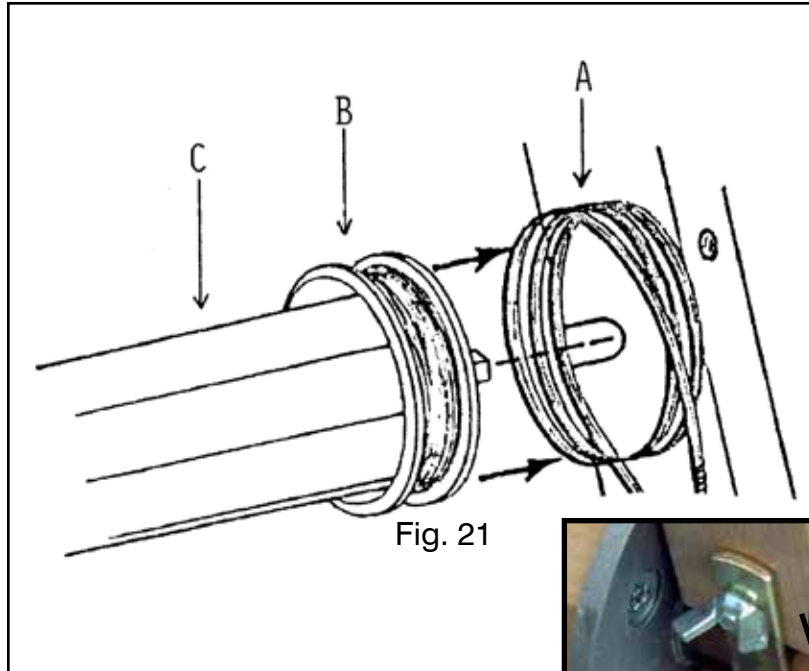
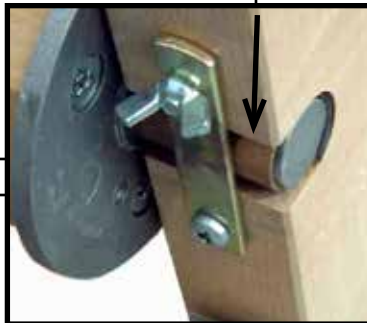

Fig. 21

### WARP BEAM INSTALLATION

Hold the circular wire brake shoe A slightly to the rear of the loom, **but do not unroll it.**

Insert the brake drum B into the wire brake shoe A. Then, install the ends of the warp beam C into the grooves of the back posts.



In order to improve the rotation of the warp beam, special bushings are supplied. Make sure to leave them in place when installing the warp beam on the loom.

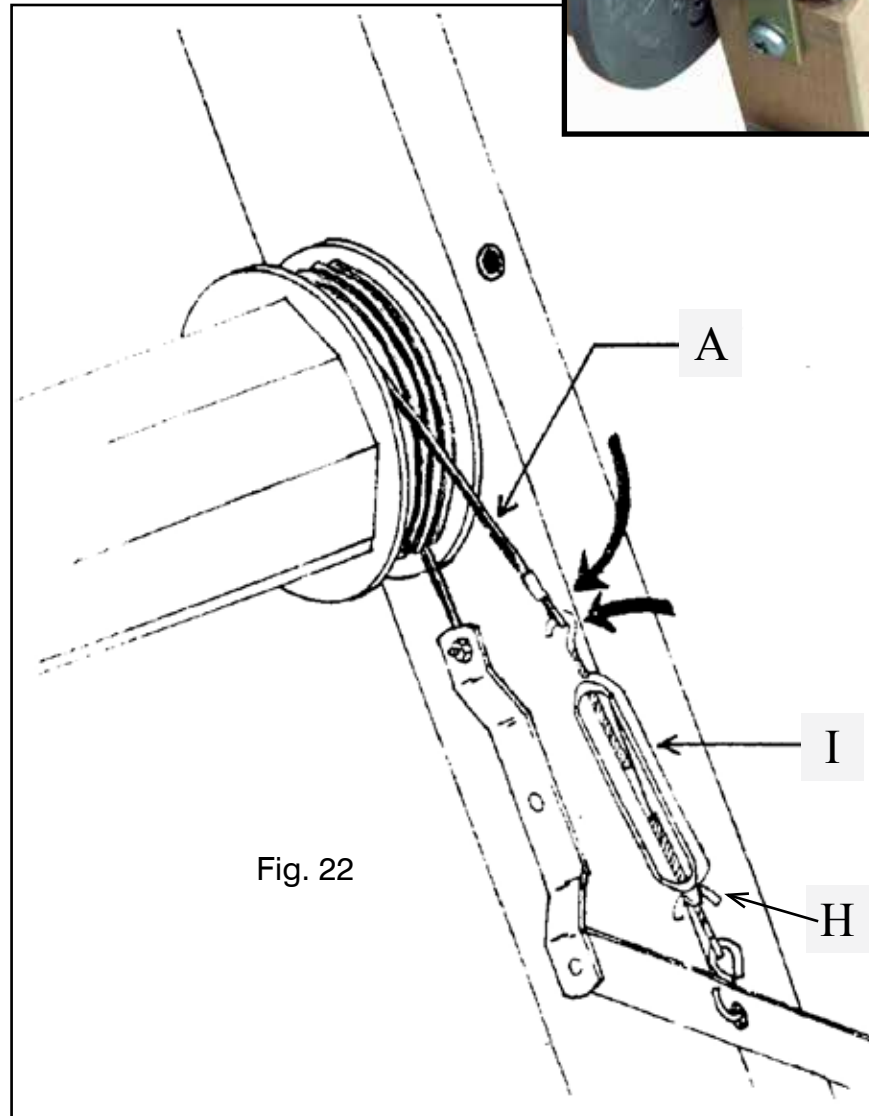
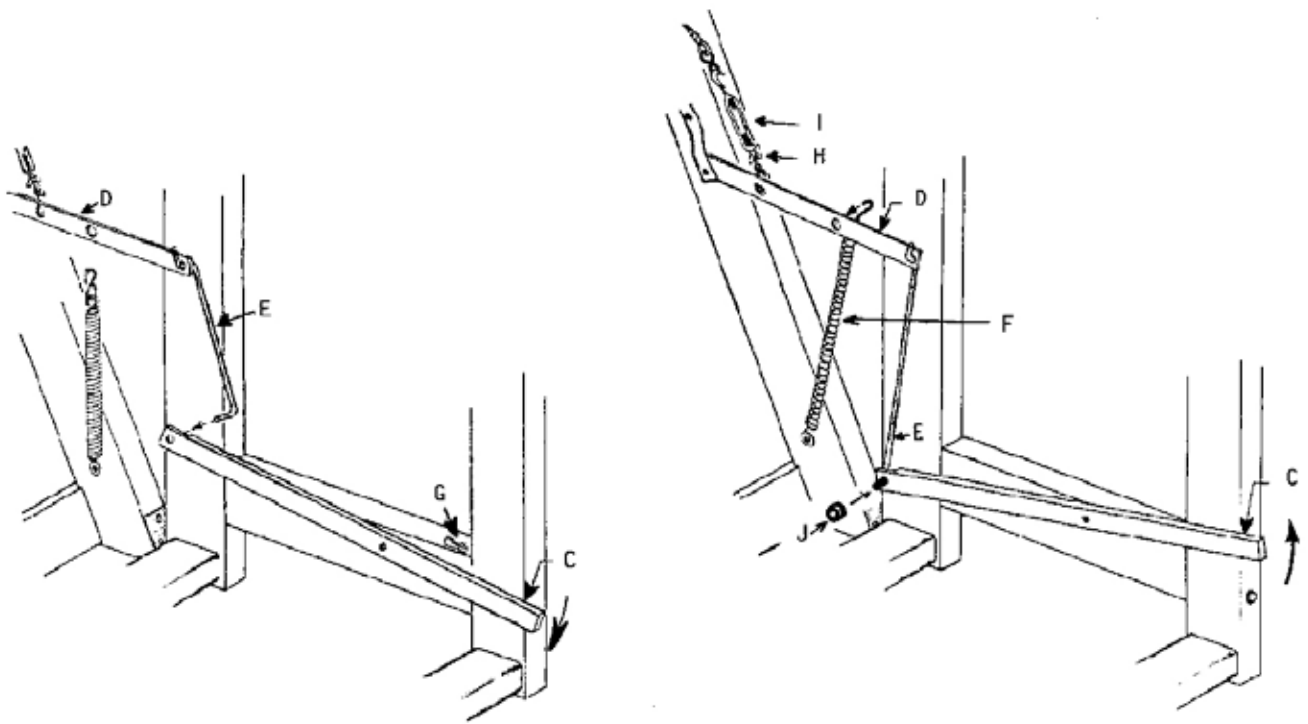

Fig. 22

Hook turnbuckle I to flat wire circle A.



If needed, make the brake treadle connection .  
 Push down and lock the brake treadle.

If the loom is equipped with a sectional warp beam,  
 the rake-like pieces must be affixed to the warp beam.  
 If not, affix the apron to the warp beam with the tacks  
 supplied with the loom.

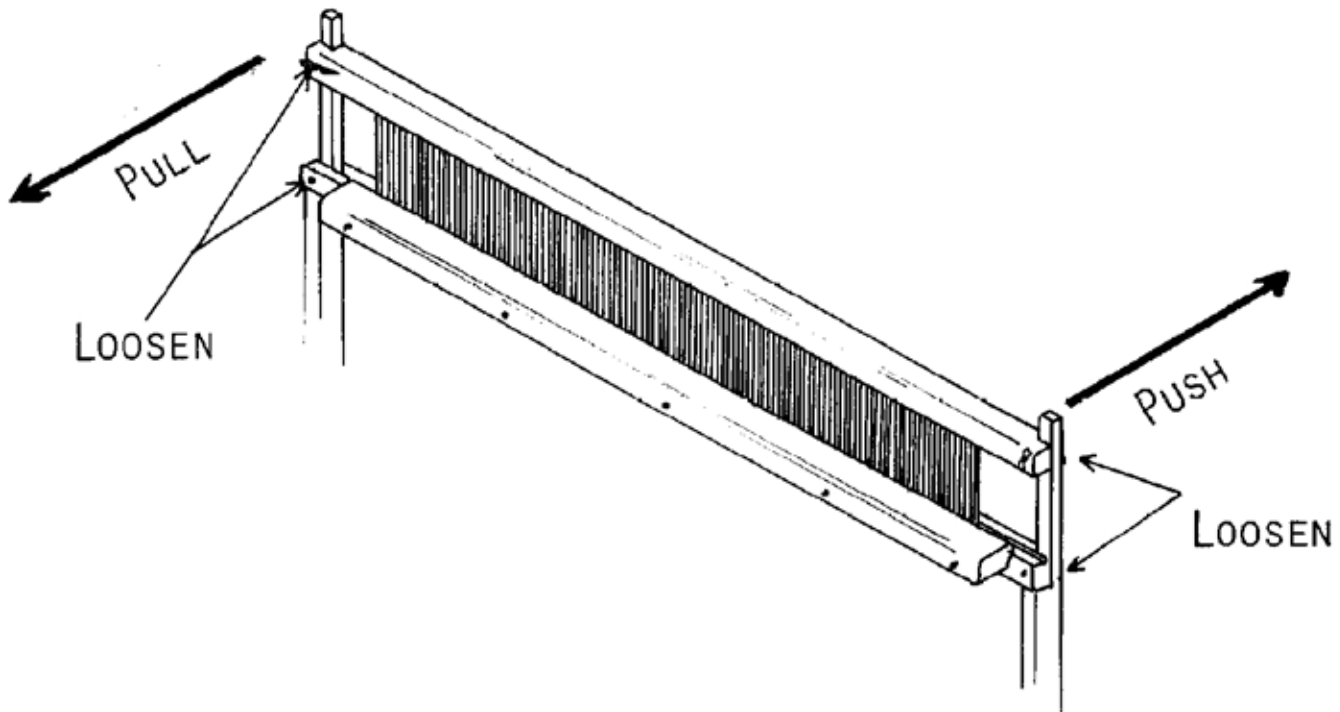
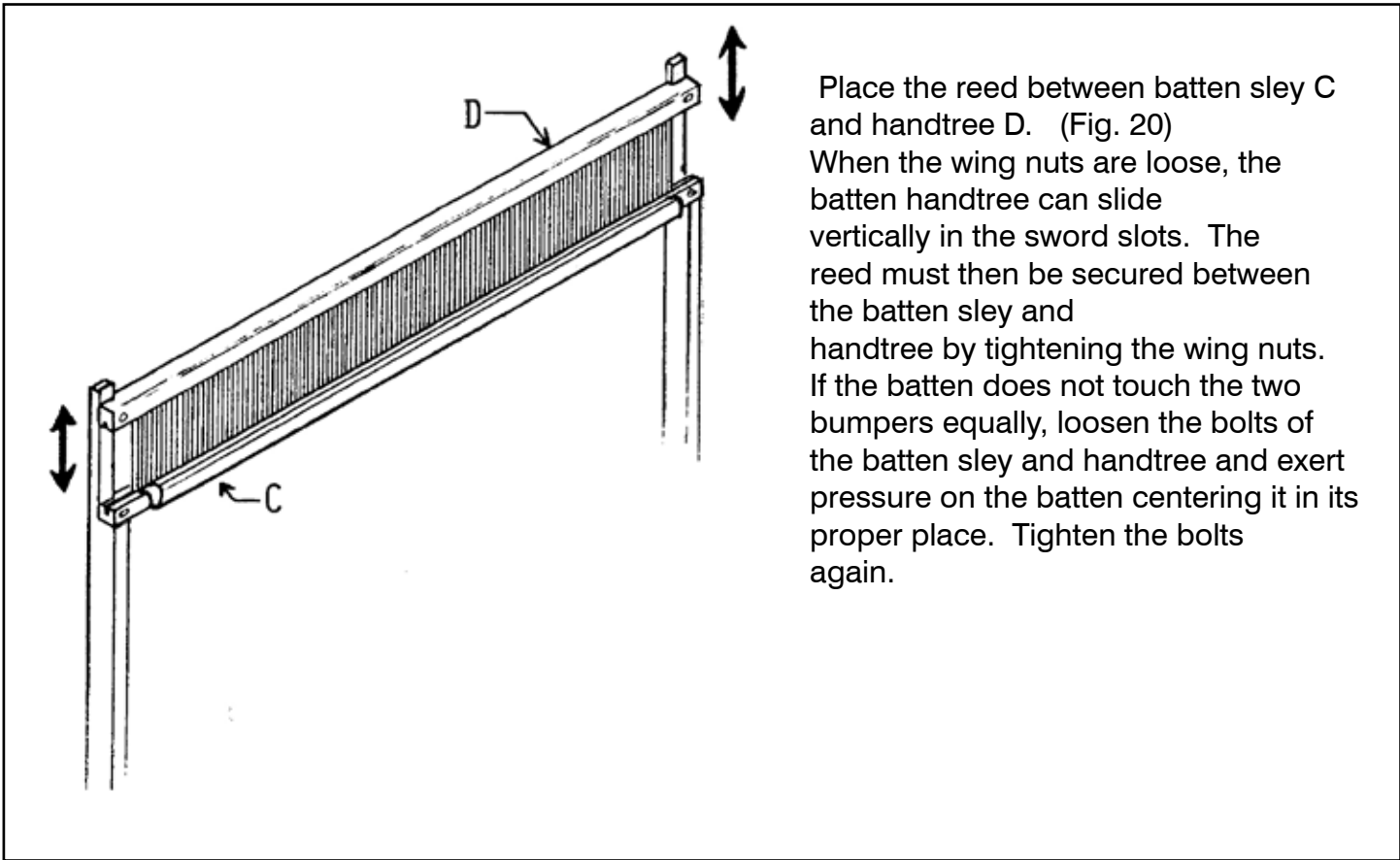

If the batten does not touch the two bumper equally, loosen the bolts of the batten sley and batten handtree and exert pressure on the batten centering it in its proper place. Tighten the bolts again while keeping pressure in the batten straight.

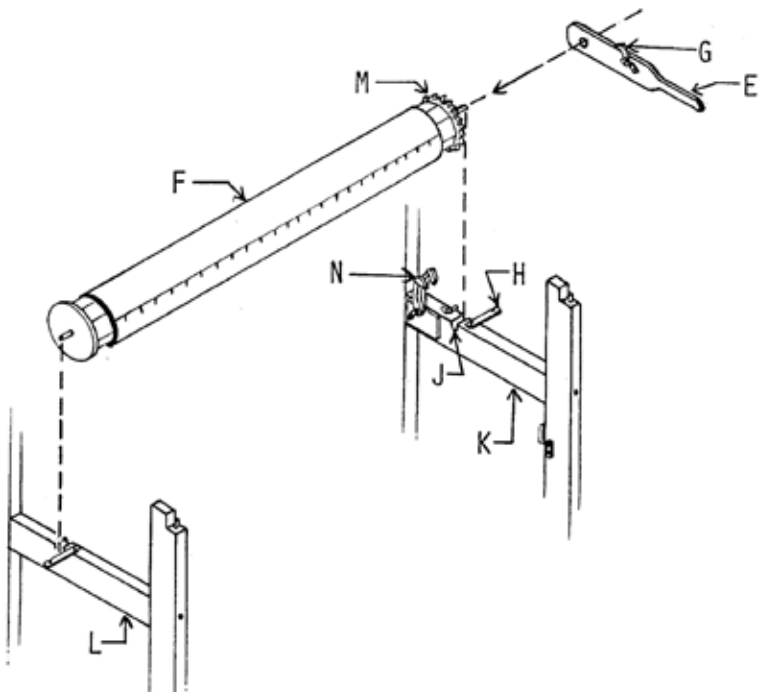

Install take-up motion handle E on the axle end of cloth beam F (on the same side as the ratchet gear) by first removing the metal bushing. The take-up handle should then be installed, taking care to ensure that the ratchet pawl G is lifted up and out of the way. Once the handle is in place, the bushing should be re-installed on the cloth beam axle.

Open beam latches H and place the beam ends in the slots J of the upper side cross- members K and L.

Note: Ratchet gear M must be on the right-hand side and ratchet pawls N must be lifted up.

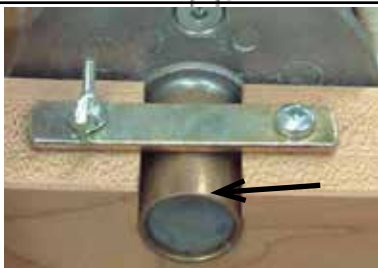

In order to improve the rotation of the cloth beam, special bushings are supplied. Make sure to leave them in place when installing the cloth beam on the loom.

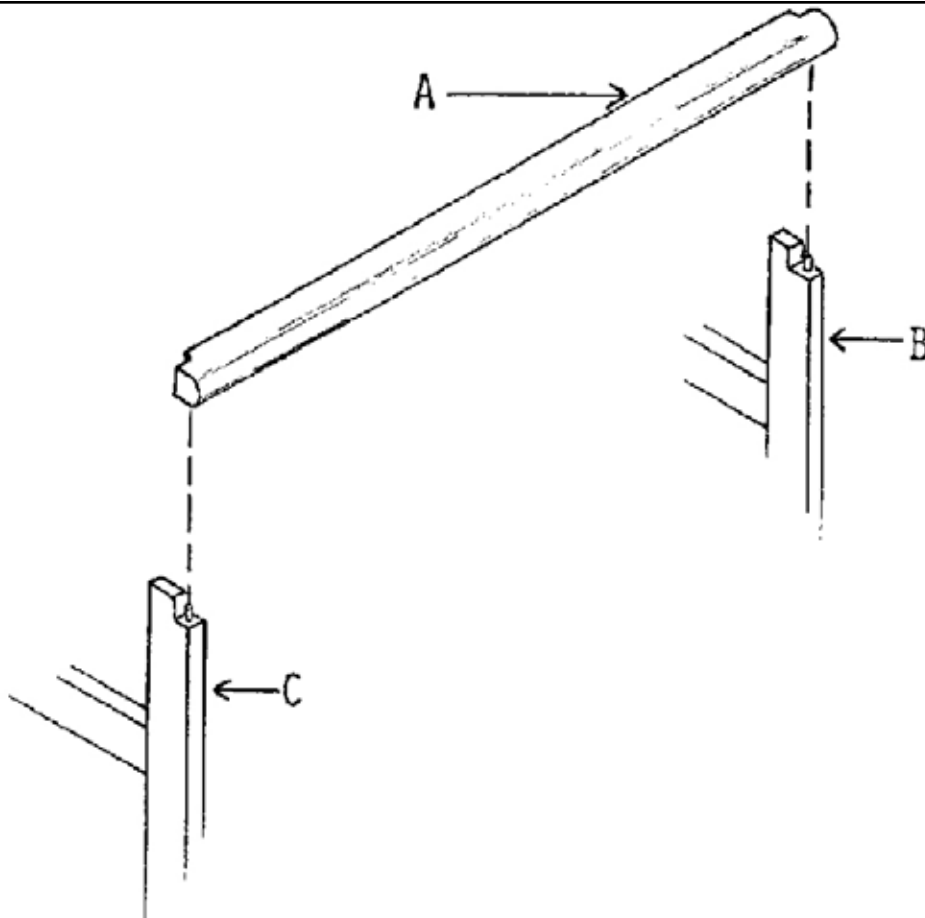

Affix one of the breast beams A on the top of the front posts B and C.

Affix the other breast beam on top of the back posts.

NOTE: To avoid splitting the front posts, slightly insert the breast beam onto the metal pin. Be sure that it is in the right position before inserting it completely.

## FOLDING LOOM AND BEAMING:

Release the brake by depressing treadle C and by locking it down with catch G. Release the 4 metal hooks and fold the back of the loom.

## WEAVING:

To advance the warp, depress brake treadle C and turn cloth beam H at the same time. Then release brake treadle C and advance the cloth beam until the next notch in the ratchet gear is reached. If this is too much tension, gently depress the brake treadle until the desired tension is obtained.

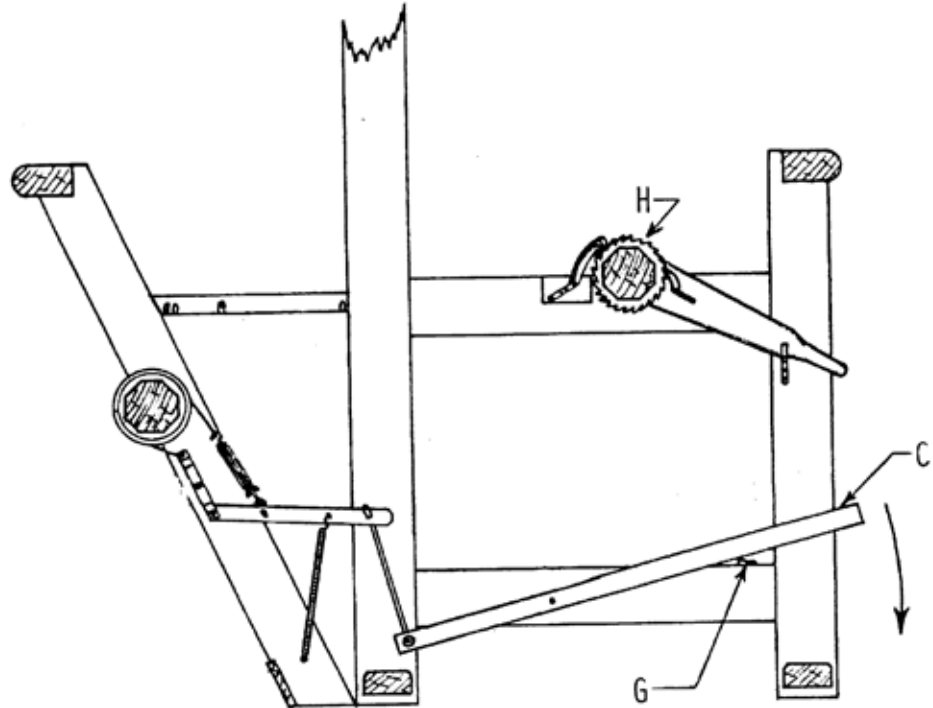

### Note while winding a warp with a Leclerc Friction Brake

To maintain proper adjustment and operation of your Friction Brake, it is recommended that the Brake be disengaged while winding the Warp.

On those looms designed with a Treadle or Lever Lock, the Brake should be locked open when winding.

### MORE INFORMATION:

See "WARP AND WEAVE"

Install the Warp beam advance control system. This system will eliminate excessive warp yarn advance when releasing the brake system at cloth take-up.

This friction system is adjustable and **have to be released when winding the warp on.**

Just screw the handle in to increase the friction or unscrew it to release.

Affix it to the back left side of the loom using 2 round head screws no 12 - 1" to the pre-drill holes.

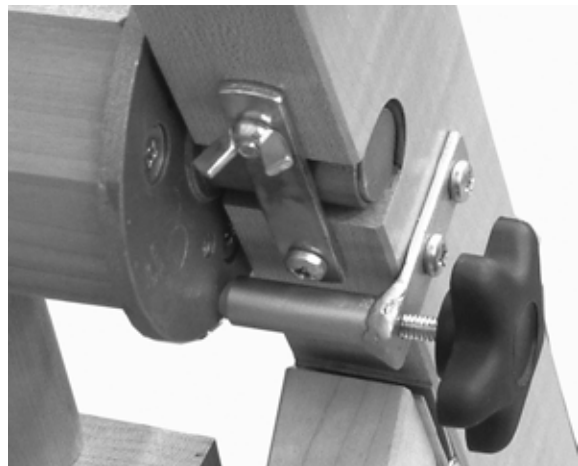



### FIRST TIE-UP

Refer to the book "Warp & Weave" supplied with the loom.



A) & B) When the shed regulator is not needed, (even shed) lock the pulleys with the metal pin. To have a nice shed, lock the pin so the warp threads pass app. at the center of the reed when the shed is close.

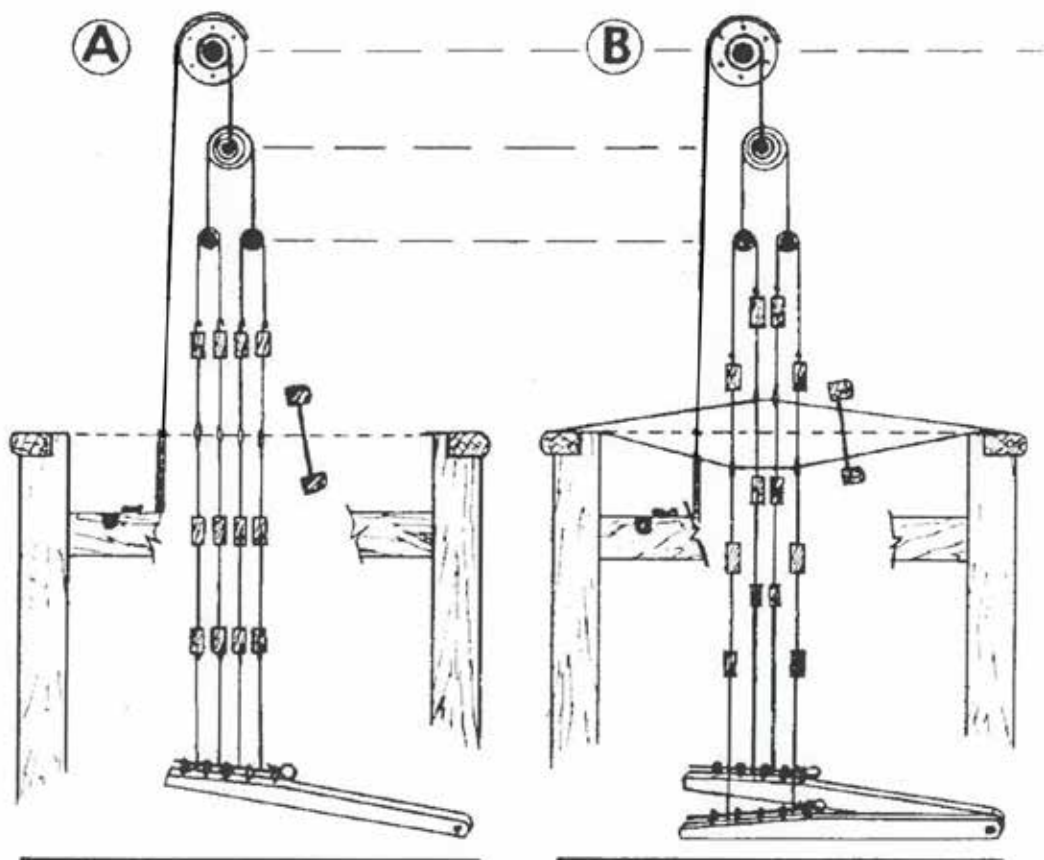

C) & D) Remove the metal pin to weave uneven shed or to weave with very high tension on the warp. Adjust the length of the loop cord so the shed is maximum with all tie-ups of the pattern.

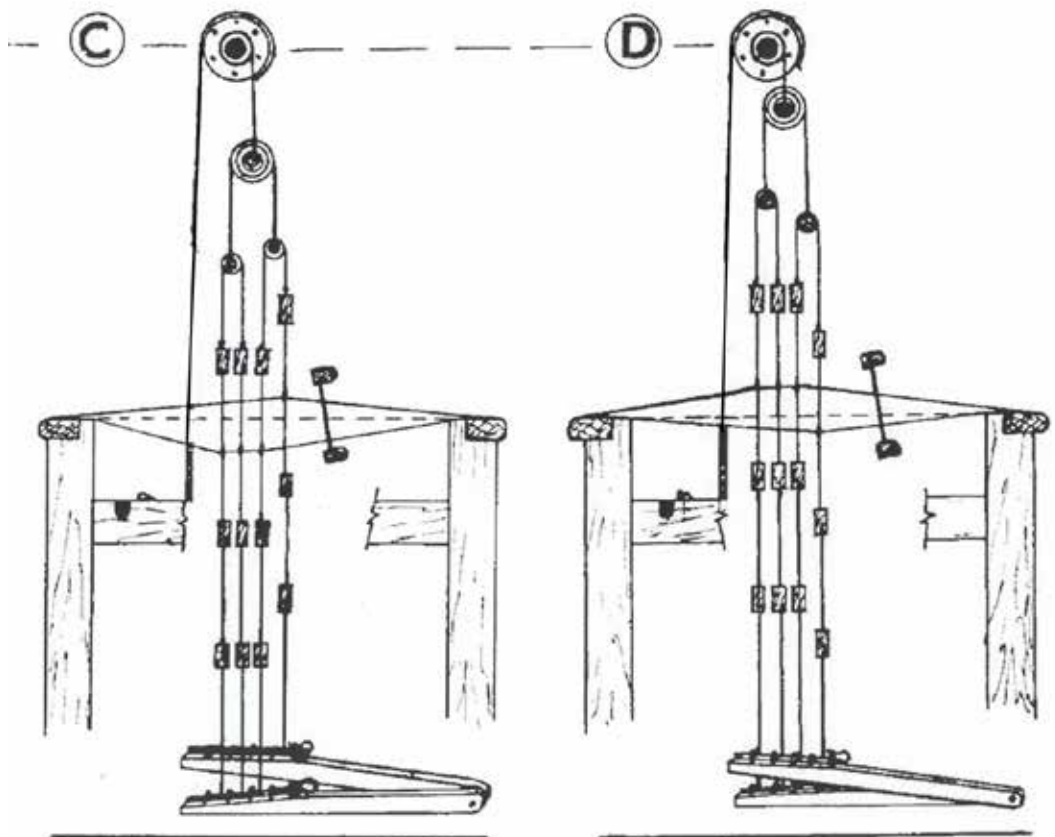

If the loom is equipped with a sectional warp beam, affix the rake-like pieces (following the instructions supplied with the sectional warp beam) and do the following instructions on the cloth beam only.

If the loom is not equipped with a sectional warp beam, affix the apron to the warp beam with tacks and do the following procedures on the warp and cloth beams.

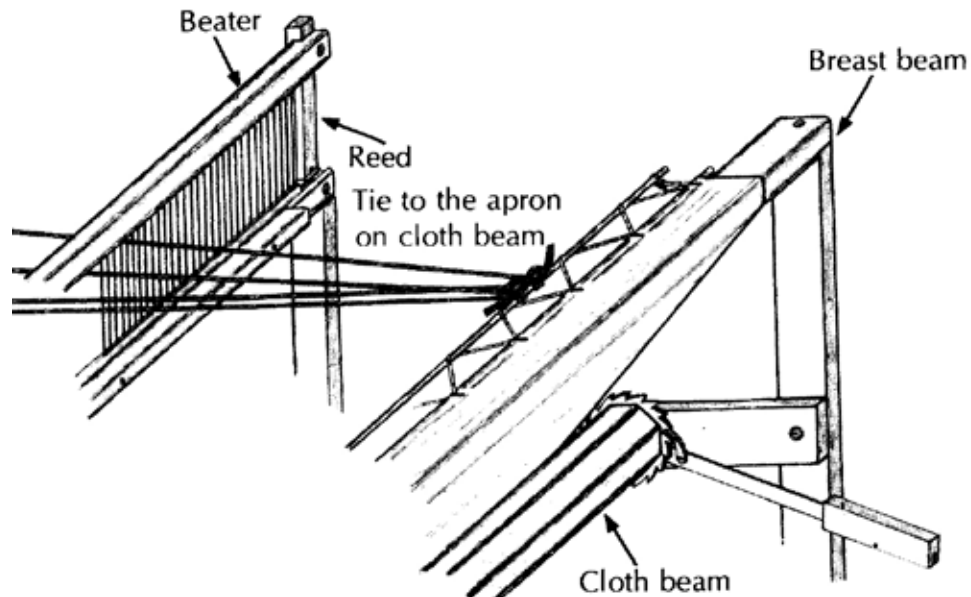

Insert a warp rod into the apron border.

For 27", 36" and 45" loom  
(70cm, 90cm and 115cm)

Cut the 5 yard (4.5m) cord in half.  
Use one half of the cord to lace the apron  
warp rod to a second warp rod. This  
second warp rod will be used to  
attach warp threads.

For 60" loom  
(150cm)

Use a 5 yard (4.5m) cord to lace the  
apron warp rod to a second warp rod.  
This second warp rod will be used to  
attach warp threads.

---

**WEAVING:** The height of the shaft frames and the beater have been pre-adjusted. Make sure the warp threads pass through the center (or close to the center) of the reed. For more information refer to the book "Warp & Weave" supplied with the loom.

**We at Leclerc encourage Weaver feedback on  
this and all our products. Please  
send your comments to Leclerc Loom Co.  
info@leclerclooms.com**

**HAPPY WEAVING**